

# MCS-10 Technical Data Sheet

## Introduction / Physical

The MCS-10 allows low-voltage control of a motorized screen. It is designed to lower or raise a screen with a 12-volt DC signal, as is supplied by many videoprojectors.

When +12V is applied to the input connector on the MCS-10, the screen will descend to its fully-lowered position. When the +12V is removed, the screen will rise to its fully rolled-up position. These two positions are set on the screen motor itself. (There is no mechanism for stopping the screen in an intermediate position.)

## Layout and Dimensions

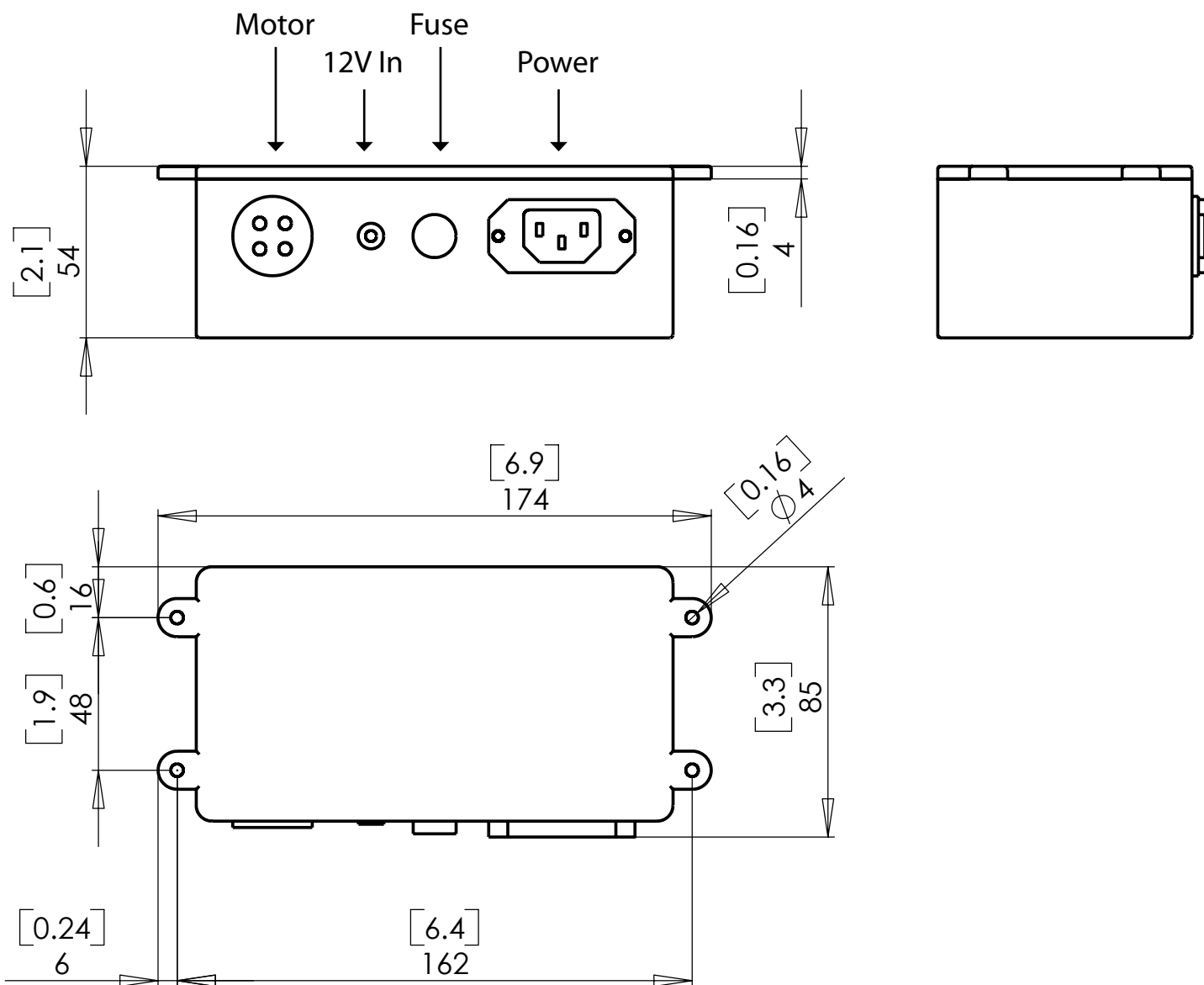

# MCS-10 Technical Data Sheet

## Electrical

---

### Pinouts

| Connector                         | Pin      | Description | 220V color on motor | 110V color on motor |
|-----------------------------------|----------|-------------|---------------------|---------------------|
| Motor                             | 1        | Ground      | Green/Yellow        | Green               |
|                                   | 2        | Down        | Brown               | Black               |
|                                   | 3        | Neutral     | Blue                | White               |
|                                   | 4        | Up          | Black               | Red                 |
| 12V<br>(1/8" mono phono)          | 1 (body) | + 12V DC    |                     |                     |
|                                   | 2 (tip)  | 0 V DC      |                     |                     |
| Power Connector<br>(IEC / CEE 22) | 1        | Phase       |                     |                     |
|                                   | 2        | Ground      |                     |                     |
|                                   | 3        | Neutral     |                     |                     |

### High-Voltage circuit characteristics

100-240VAC, 12A max.

### Fuse

5 x 20 mm, 3.15A fast-acting

### Low-Voltage circuit characteristics

Input: 10-14V DC

Power consumption: 30mA @ 12V

---

### Screen Research

Rue du Finistere

ZAC Erdre Active

44240 La Chapelle sur Erdre, France

Tel. +33 (0) 2 40 77 87 89 Fax +33 (0) 2 40 77 86 78

<http://www.screenresearch.com>

[info@screenresearch.com](mailto:info@screenresearch.com)